

***CSC Valves
Canada Inc.***

Series CSCW2 – Cast Threaded Ball Valve



Cast two-piece seal welded construction, 2000 PSI WOG, reinforced PTFE seats, SS trim, blowout-proof stem, and standard locking handle.

NPT ends in accordance with ASME B1.20.1

Rated to 2000 PSI for 3" FP WOG

NACE MR 0175 / ISO 15156 upon submission of application data

API 607 Firesafe

$$Q = \sum_{n=1}^{\infty} AS_n$$



“Quality equates to the sum of Applied Science”

Serving the most rugged applications in the Western Canadian Sedimentary Basin
CSCW2 Series – February 2022

CSC Valves Canada Inc.

Series CSCW2 – Cast Threaded Ball Valve

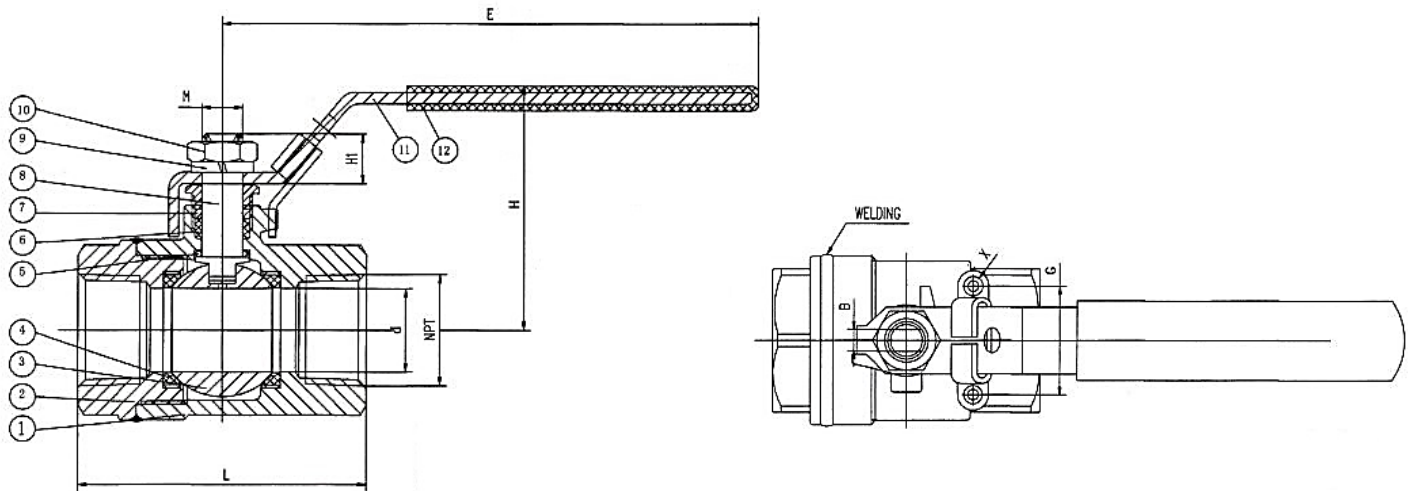

Size		d		H		E		L		B		M
in	mm	in	mm	in	mm	in	mm	in	mm	in	mm	mm
1/4"	8	0.42	10.8	2.00	51	4.13	105	2.08	53	0.19	5	8
3/8"	10	0.49	12.5	2.00	51	4.13	105	2.08	53	0.19	5	8
1/2"	15	0.59	15	2.56	65	4.72	120	2.48	63	0.19	5	8
3/4"	20	0.78	20	2.68	68	4.72	120	2.83	72	0.23	6	10
1"	25	0.98	25	2.87	73	6.10	155	3.38	86	0.27	7	12
1 1/4"	32	1.25	32	3.18	81	6.10	155	3.93	100	0.27	7	12
1 1/2"	40	1.49	38	3.58	91	7.48	190	4.25	108	0.39	10	16
2"	50	1.96	50	3.94	100	7.48	190	4.84	123	0.39	10	16
2 1/2"	65	2.52	64	5.98	152	11.81	300	7.28	185	0.59	15	22
3"	80	2.99	76	5.37	136.5	15.75	400	6.89	175	0.59	15	22

No.	PART NAME	MATERIAL	QTY
1	BODY	ASTM A216 WCB	1
2	CAP	ASTM A216 WCB	1
3	BALL	ASTM A182 F316	1
4	SEAT	RPTFE	2
5	THRUST WASHER	PTFE	1
6	STEM	ASTM A276 F316	1
7	O-RING	VITON-GLT 90 DUR	2
8	WASHER	DELTRIN	1
9	LOCKABLE PLATE	ASTM A240 201	1
10	JUMP RING	CS	1
11	HANDLE	ASTM A216 WCB	1
12	BOLT	CS	1

