

**CSC Valves  
Canada Inc.**

## Series FBT3 – Forged Sour Low Temp Ball Valve



Forged three-piece threaded construction, SS trim, Delrin seats, blowout-proof stem, standard locking handle, 3000 PSI WOG. Body constructed with A350 LF2 or F316 steel for low temperature sour gas service.

NPT ends in accordance with ASME B1.20.1

Rated to 3000 PSI for sizes 1/4-1/2" FP, and 3/4" to 2" RP WOG

NACE MR 0175 / ISO 15156 upon submission of application data

ASME B16.34 Design

API 607 Firesafe

$$Q = \sum_{n=1}^{\infty} AS_n$$



**"Quality equates to the sum of Applied Science"**

Serving the most rugged applications in the Western Canadian Sedimentary Basin  
FBT3 Series – February 2022

# CSC Valves Canada Inc.

## Series FBT3 – Forged Sour Low Temp Ball Valve

No.	PART NAME	MATERIAL	QTY
1	CAP	ASTM A350 LF2	2
2	SEAT	DELFIN	2
3	BALL	ASTM A479 F316	1
4	THRUST WASHER	DELFIN	1
5	PACKING	GRAPHITE	1
6	GLAND	SS304	1
7	BEVEL WASHER	SS301	1
8	NUT	A2-70	1
9	STEM	ASTM A479 F316	1
10	LOCKHOLE FLANGE	CS	1
11	BODY	ASTM A350 LF2	1
12	O-RING	VITON GLT 90 DUR	2
13	WASHER	GRAPHITE	2
14	HANDLE	WCB	1
15	BOLT	CS	2
16	O-RING	VITON GLT 90 DUR	1

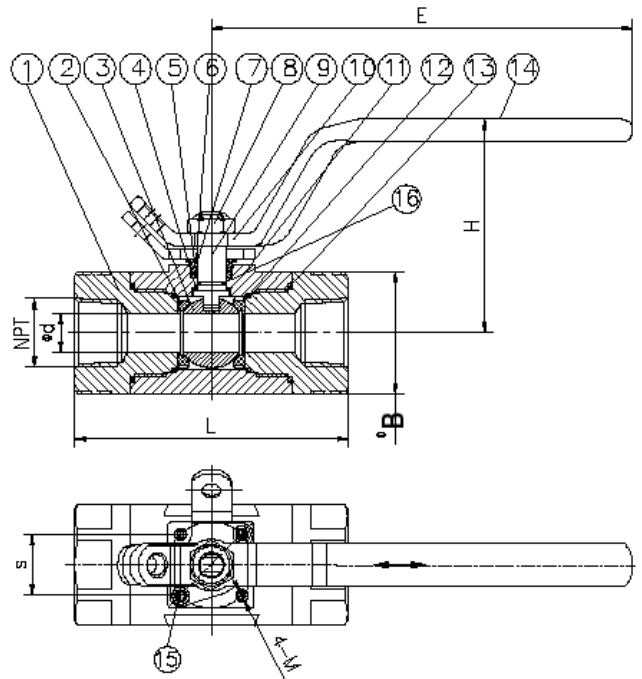

Size		Ød		L			H		E		S		M	ØD		ØB	
in	mm	in	mm	in	mm	mm	in	mm	in	mm	in	mm	mm	in	mm	in	mm
1/2"	15	0.50	12.70	3.86	98.00	+ / - 1.4	2.95	98	6.49	165	1.00	25.40	M5	1.42	36	1.63	41.5
3/4"	20	0.69	17.50	4.25	108.00		3.54	108	8.07	205	1.16	29.50	M5	1.65	42	1.97	50
1"	25	0.88	22.30	4.25	108.00		3.66	108	8.07	205	1.16	29.50	M5	1.65	42	2.32	59
1 1/2"	40	1.25	31.80	5.24	133.00	+ / - 1.6	4.96	133	10.04	255	1.39	35.30	M6	1.97	50	3.11	79
2"	50	1.50	38.00	6.26	159.00		6.10	159	12.20	310	1.95	49.50	M8	2.76	70	3.58	91

